

ET-XCRP Reference Manual

Revision: August 30, 2002

Overview

The ET-XCRP (XCRP) circuit board featuring the Xilinx CoolRunner XC3064 CPLD provides a very low cost platform that can be used to implement a wide variety of digital circuits, from complex combinational devices to sequential machines and controllers. The XCRP board provides an ideal platform for new engineers requiring experience with basic digital design techniques, as well as those needing exposure to Xilinx CAD tools and CPLD devices. XCRP board features include:

- A socketed Xilinx XCR3064 CPLD;
- Non-volatility – designs remain in the CPLD after power is removed;
- On board voltage regulator for use with a wall-plug transformer, or the board can run more than 60hrs on 2 AA cells (typical);
- Expandability –an integral solderless breadboard allows expansion circuits to be constructed right on the XCRP board;
- An user-adjustable oscillator circuit (approximately 0.5Hz to 4KHz);
- JTAG programming using a standard parallel cable (included);
- Two high-bright seven segment displays;
- Four debounced buttons;
- Eight slide switches;
- Eight LEDs in three colors (red, green, and yellow);
- 40-pin expansion connector.

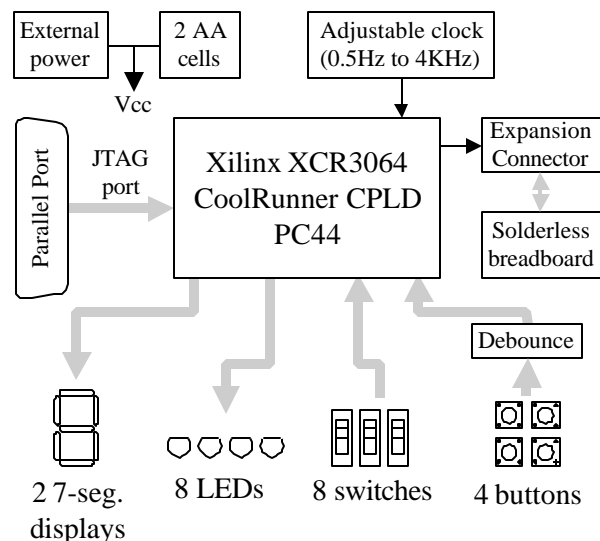

Figure 1. XCRP circuit board block diagram

The DXCR board makes an excellent platform for instructional-lab based work: it is fully compatible with all versions of the Xilinx CAD tools, including the free WebPack tools available at the Xilinx website; the included CPLD uses non-volatile configuration memory, so designs can be completed outside the lab; and the board ships with a programming cable and a power source, so designs can be implemented immediately without the need for any additional hardware.

Functional description

The XCRP board has been designed to offer a low-cost system for designers who need a flexible platform to gain exposure to the basics of digital design or to CPLD devices. The XCRP board provides sufficient I/O devices so that many interesting circuits can be implemented without the need for any other devices. All CPLD signals are routed to an expansion connector so that designs can easily be extended using the on-board solderless breadboard, or by attaching accessory boards. The board can run on two AA cells, so designs are portable. It includes a XCR3064 CoolRunner CPLD, a JTAG configuration circuit that uses a standard parallel cable, an user-settable oscillator circuit, and several useful I/O devices.

Table 1 shows all signals routed on the XCRP board. These signals and their circuits are described in the following sections.

Power Supplies

VBAT	Battery voltage
VEXT	External voltage applied to J4
VCC	System voltage at SW9, equal to either VBAT or VEXT
GND	System ground routed to all devices

Programming parallel port

TDI	JTAG data input signal
TCK	JTAG clock signal
TMS	JTAG test mode select signal
TDO	JTAG data out signal

On board devices

MCLK	Master clock from user-settable oscillator circuit
BTN1-4	Debounced button inputs
SW1-8	Slide switch inputs
LED1-8	Individual LED drive signals
CAT1, 2	Common cathode signals for seven-segment displays
AA-AG	Anode signals for seven segment displays

Expansion Connector

NA	All named signals routed to expansion connector (except MCLK)
----	---

Table 1. XCRP board signal definitions

Parallel port and FPGA configuration circuit

The XCRP board uses a DB-25 parallel port connector to route JTAG programming signals from a host computer to the CPLD. The programming circuit simply connects the parallel port pins driven by the Xilinx CAD tools directly to the CPLD programming pins, making the board fully compatible with all Xilinx programming tools.

To configure the board from a computer using the JTAG mode, ensure the circuit is powered either by batteries or by an external power supply. Before running Xilinx's iMPACT programmer tool to download a bit file, ensure that the JTAG start-up clock is selected in the "Generate Programming File" properties dialog box. Attach the programming cable, and start the iMPACT programmer. The board will be auto-detected by the Xilinx software, and all normal JTAG operations will be available. Operations are available in a pull-down menu made visible by right clicking on the device graphic in the iMPACT programmer window.

Programming circuit detail is shown below.

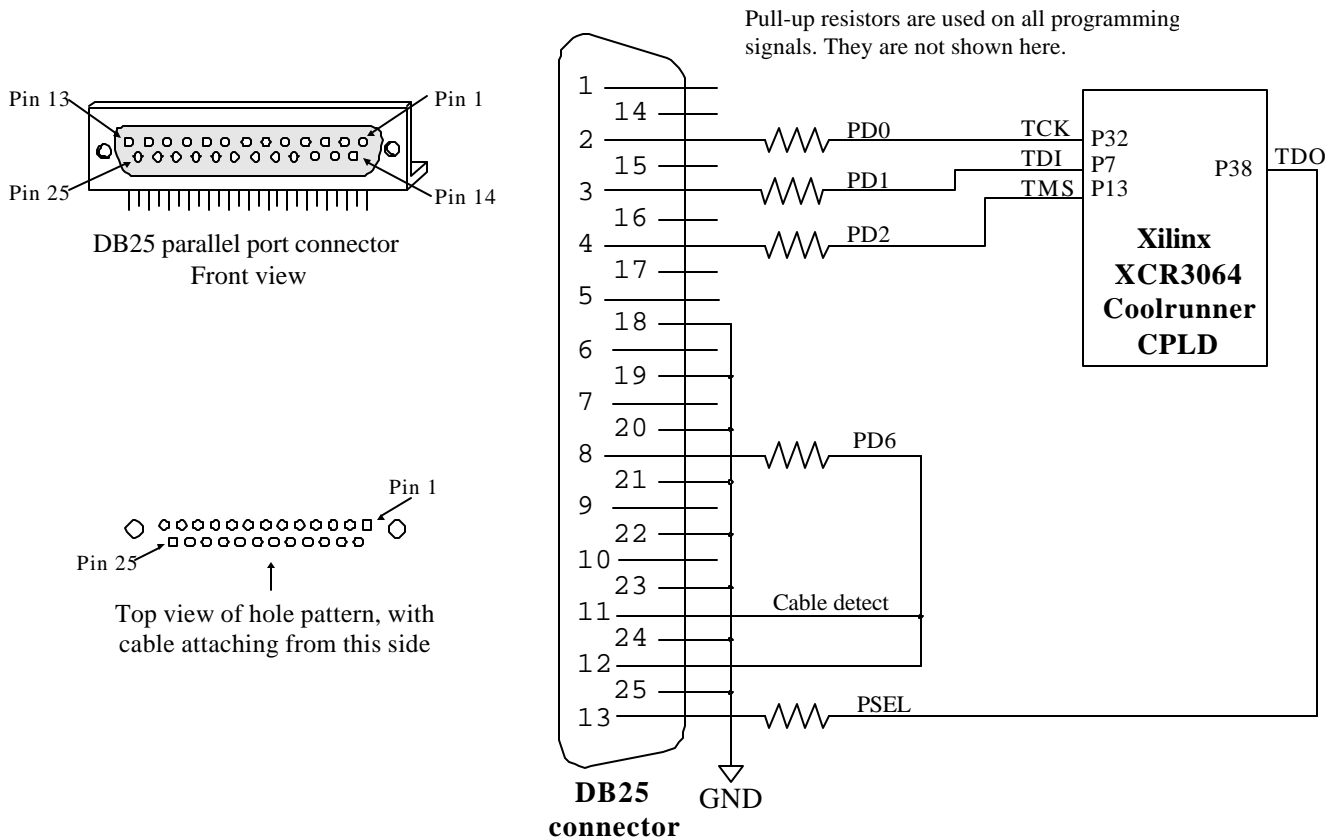

Figure 2. Parallel port connectors and signals

Oscillator

The XCRP board provides an user-adjustable oscillator that can produce a clock signal in the 0.5 to 4KHz range. The oscillator circuit uses an auto-feedback Schmidt-trigger inverter, with a variable resistor and fixed 4.7uF capacitor in the feedback path. The variable resistor is a 15-turn precision potentiometer that can be adjusted from 0 to 500K ohms, providing an RC time constant that varies by several orders of magnitude. This clock source provides an adequate frequency range for experiments that run from “human time” (i.e., less than 1 Hz) to the audio range. The oscillator output drives the CLK0 input of the CPLD via a second Schmidt trigger.

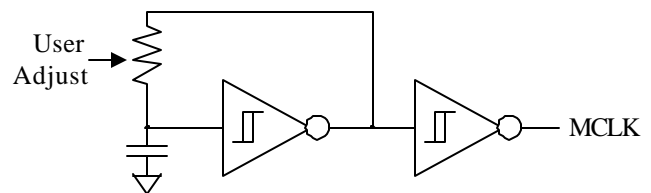

Figure 3. Oscillator circuit

Power Supplies

The XCRP board can be powered from any wall-plug transformer that uses a 2.1mm center-positive jack, and that produces at least 100mA in the 5VDC to 9VDC range. The board can also be powered from 2AA cells or any other power source that outputs at least 100mA at 2.5 to 4.0 volts. The secondary power source connector bypasses the on-board regulators, so if that connector is used, ensure that no more than 4VDC is applied to the board. During operation, the board consumes less than 80mA with all LEDs and LED segments illuminated.

LEDs

Eight LEDs (four red, two yellow, and two green) are provided for circuit outputs. LED anodes are driven directly from the CPLD via 470-ohm resistors, and the cathodes are connected directly to ground. The CPLD connection point is also available at the expansion connector via a 470-ohm resistor. Three colors are offered so that circuits like traffic light controllers or basic meters can easily be implemented. A ninth LED is also provided as a power-on LED.

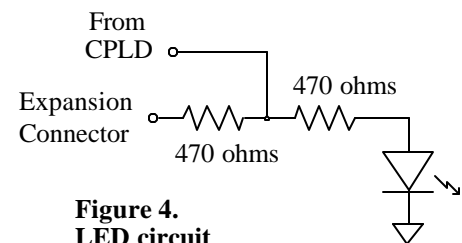

Figure 4.
LED circuit

Pushbutton

Four debounced pushbuttons are provided for circuit inputs. Buttons are debounced with an RC-Schmidt trigger circuit so that they may be used as clocks for basic sequential circuits. Button outputs (at the output of the Schmidt trigger) are normally low, and they are driven high only when the button is pressed. Button outputs are available at the expansion connector.

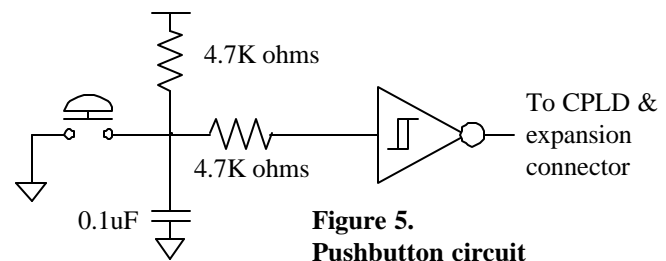

Figure 5.
Pushbutton circuit

Slide Switches

Eight slide switches are provided for circuit inputs. The slide switches use a 4.7Kohm series resistor for nominal input protection. Switch outputs are available at the expansion connector.

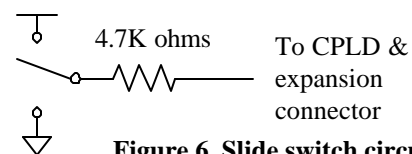

Figure 6. Slide switch circuit

Seven Segment Display

The XCRP board contains a modular 2-digit, common cathode, seven-segment LED display. In a common cathode display, the seven cathodes of the LEDs forming each digit are connected to a common circuit node. On the XCRP board, the two-digit display has two common cathode nodes labeled CAT1 and CAT2. Both cathodes, and therefore both digits, can be independently turned on and off by driving the CAT1/2 signals to a '1' or a '0' respectively. The anodes of similar segments on

both displays are also connected together into seven common circuit nodes labeled AA through AG. Thus, each anode for both displays can be turned on and off independently. This connection scheme creates a multiplexed display, where driving the cathode signals and corresponding anode patterns of each digit in a repeating, continuous succession can create a stable 2-digit display. Even though each digit is illuminated only half time, the human eye will be “tricked” into seeing continuously illuminated digits (this phenomenon is used by all multiplexed displays, including televisions, computer monitors, and motion pictures). To appear bright and continuously illuminated, both digits should be driven once every 1 to 16ms (for a refresh frequency of 1KHz to 60Hz). For example, in a 60Hz refresh scheme, each digit would be illuminated for 1/2 of the refresh cycle, or 8ms.

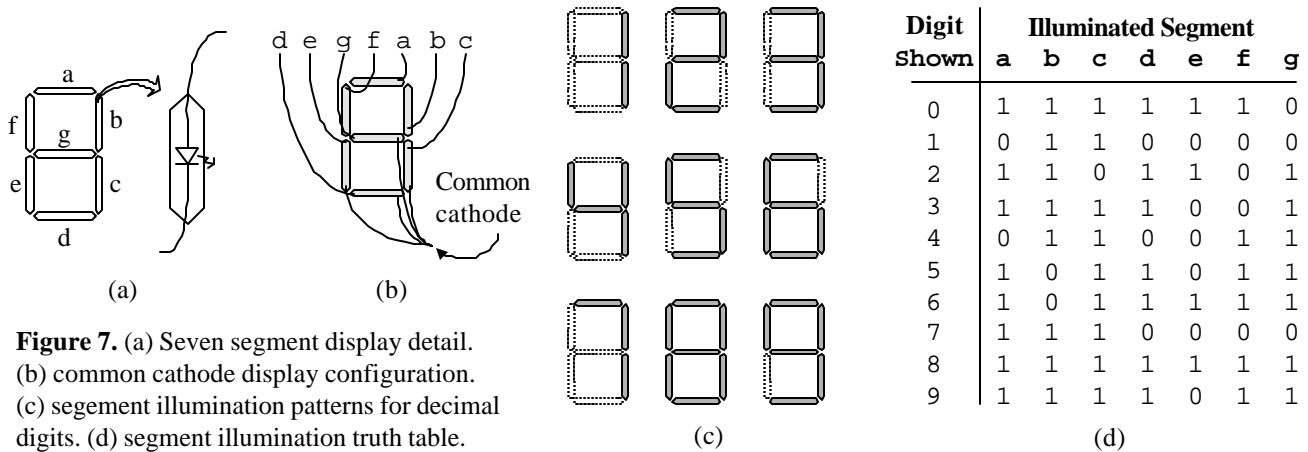
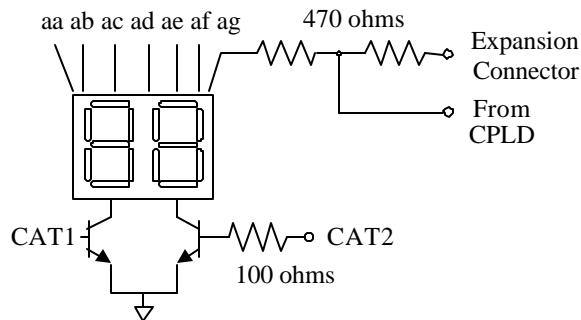

Figure 7. (a) Seven segment display detail. (b) common cathode display configuration. (c) segment illumination patterns for decimal digits. (d) segment illumination truth table.

A display controller must assure that the correct anode pattern is present when the corresponding cathode signal is driven. To illustrate the process, if CAT1 is driven high while AB and AC are driven high, then a “1” will be displayed in digit position 1. Then, if CAT2 is driven high while AA, AB and AC are driven high, then a “7” will be displayed in digit position 2. If ACAT1/AB, AC are driven for 8ms, and then CAT2/AA, AB, AC are driven for 8ms in an endless succession, the display will show “17” and the observer cannot tell that both digits are not continuously illuminated. An example timing diagram is provided below.

Anodes are connected to CPLD via 470-ohm resistors (and to expansion connectors via more 470 ohm resistors)



Cathodes connected to ground via two transistors driven from the CPLD and expansion connectors

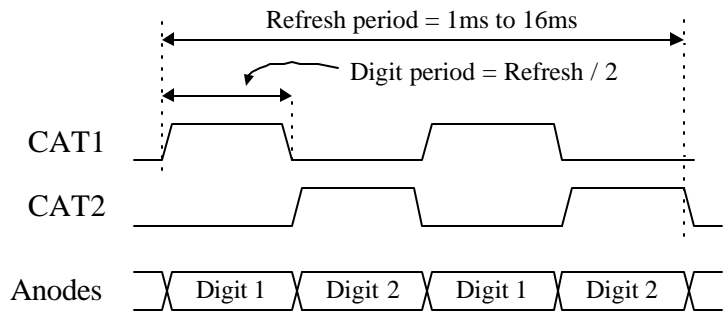

Timing diagram showing multiplex timing requirements

Figure 8. Dual-digit common cathode display and timing diagram

The seven-segment display anodes are driven from the CPLD pins via 470 resistors, and the cathodes are driven by two 2N3904 NPN transistors to supply the required cathode current. The 3904 bases are driven from the CPLD via 100-ohm resistors. The CPLD connection point is also available at the expansion connector via a 470-ohm resistor.

Expansion connector

An expansion connector labeled J3 on the board edge has been provided so that designs can easily be extended beyond the XCRP board. The connector uses a 2 x 20, 100-mil spaced grid so that standard headers or sockets may easily be loaded (no expansion connector is loaded during manufacturing to allow greater flexibility). All available CPLD signals are routed to the connector, including signals that drive on-board devices. Where feasible, on-board devices are decoupled from the CPLD with series resistors so that all pins may be used as inputs or outputs by the expansion connector. VCC and GND are also routed to the connector so that attached devices can draw power from the DXCR board.

Pin	Signal	Pin	Signal	Pin	Signal	Pin	Signal
1	GND	11	SW4	21	AD	31	NC
2	NC	12	LED5	22	BTN2	32	SW5
3	VCC	13	LED9	23	AC	33	NC
4	LED1	14	LED6	24	BTN3	34	SW6
5	SW1	15	AG	25	AB	35	NC
6	LED2	16	LED7	26	BTN4	36	SW7
7	SW2	17	AF	27	AA	37	NC
8	LED3	18	LED8	28	CAT1	38	SW8
9	SW3	19	AE	29	NC	39	NC
10	LED4	20	BTN1	30	CAT2	40	IO1

CPLD

The Xilinx CoolRunner XCR3064 CPLD on the XCRP board uses a 44-pin PLCC package, with four used for VCC connections, three for GND, and five for JTAG programming. All remaining 32 I/O pins are routed to the expansion connector, and 31 are also routed to on-board devices (4 for pushbuttons, 8 for slide switches, 8 for LEDs, 10 for the seven-segment device and one for the system clock).

The CPLD device can be configured using the Xilinx JTAG tools and a parallel cable connecting the XCRP board and the host computer. A separate JTAG header that connects directly to the JTAG pins is also provided so the Xilinx programming cable can be used.

The XCRP board can also accommodate a XCR3032 CPLD. For further information on the CoolRunner CPLD, please see the Xilinx data sheets available at the Xilinx website (www.xilinx.com).

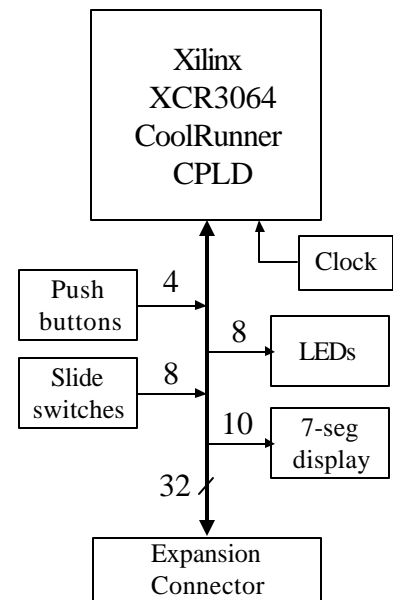

Figure 9. CPLD connections

Pin	Function	Pin	Function	Pin	Function	Pin	Function
1	BTN1	12	SW8	23	VCC	34	LED7
2	MCLK	13	TMS	24	AF	35	VCC
3	VCC	14	SW7	25	AE	36	LED5
4	BTN4	15	VCC	26	AD	37	LED4
5	SW1	16	SW6	27	AC	38	TDO
6	SW2	17	SW5	28	AB	39	LED3
7	TDI	18	CAT1	29	AA	40	LED2
8	SW3	19	CAT2	30	GND	41	LED1
9	SW4	20	LED9	31	LED8	42	GND
10	PORTEN	21	AG	32	TCK	43	BTN3
11	IO1	22	GND	33	LED6	44	BNT2